

6025RG



Fountains - Pools - Free Standing

The 6025RG freestanding underwater fixture is designed for use in medium to large decorative fountains and reflection pools using up to 250 watt PAR38/R40 incandescent lamps. The 6025RG is manufactured of marine grade cast bronze and includes a marine grade cast bronze rock guard as standard. It is fully adjustable by way of a swivel yoke assembly to optimize any lighting effect.

Specifications

Housing:

Heavy-duty marine grade cast bronze. Housing includes naval brass cord seal.

Rockguard:

Marine grade cast bronze (standard).

Swivel Yoke:

Marine grade cast bronze. Height is adjustable from 10 5/8" minimum to 14" maximum. Stand is nickel bronze alloy.

Lens / Gasket:

Lens is clear, high-temperature tempered glass. Optional colored lenses available. Gasket is a single-piece, high-temperature silicone.

Fasteners:

Stainless steel.

Lamps:

250W R40 or 150W PAR38 incandescent maximum. Lamps are not included.

Thermal Cutoff:

Integral and furnished as standard on all fixtures. This enables fixture to be used in accordance with NEC Article 680-51 in installations without an external low-water cutoff.

Socket:

Porcelain medium base.

Wiring:

Standard 15' of 16-3 STO-WA water-resistant cord. Fixture is pre-wired and potted to prevent water entry.

Warranty:

Three year limited warranty.

Certification:

UL Listed to U.S. and Canadian safety standards for submersion in fountains and decorative pools.

Accessories:

(Must Be Ordered Separately and Field Installed)

JB1:

Junction Box-2 lights, 10.5 cubic inches. Singles 3/4" N.P.T. bottom. (2) 1/2" or 3/4", one each end.

JB2:

Junction Box-4 lights, 21.3 cubic inches. (2) 1" max. N.P.T. bottom. (4) 1/2" or 3/4", one each end.

JB4:

Junction Box-8 lights, 40 cubic inches. (2) 1-1/4" N.P.T. bottom. (8) 1/2" or 3/4", two each side.

JB6:

Junction Box-12 lights, 125.7 cubic inches. (2) 2" N.P.T. bottom. (20) 1/2" or (16) 3/4", sides.

CC50:

Machined Naval Brass Cord Seal-Neoprene packing seal, brass friction ring. 1/2" N.P.T. for use with 16-3 STO-WA entry into junction box.

CC75:

Machined Naval Brass Cord Seal-Neoprene packing seal, brass friction ring. 3/4" N.P.T. for use with 10-3 STO-WA entry into junction box.

EC34:

Stainless steel waterproofing penetration fitting. 3/4" N.P.T. x 8" long for use with supply conduit into junction box.

EC1:

Stainless steel waterproofing penetration fitting. 1" N.P.T. x 8" long for use with supply conduit into junction box.

6025RG

Project:

Fixture Type:

BLU=Blue
 RED=Red
 GRN=Green
 AMB=Amber

Ordering Logic

Wattage/Lamp	Model No.	Optional Lens	Voltage
250W PAR38/R40	6025RG	()	120

Note: Lamp not included

Model No:
6025RG

Optional Lens:

Dimensions

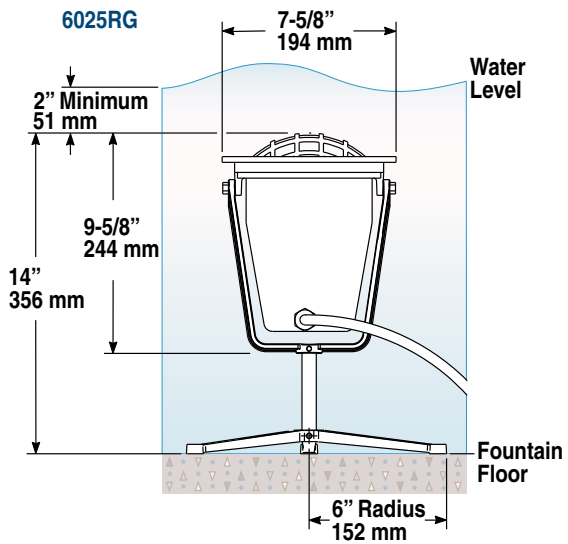

Project Notes:

Approval:

Any dimension on this sheet is to be assumed a reference dimension and used for information purposes only. It does not govern manufacturing or inspection requirements.

Bronzelite®

100 Craftway Drive • Littlestown, PA 17340
 800 273-1569 • Fax 717 359-9545 www.bronzelite.com

Some luminaires use fluorescent or high intensity discharge (HID) lamps that contain small amounts of mercury. Such lamps are labeled "Contains Mercury" and/or with the symbol "Hg." Lamps that contain mercury must be disposed of in accordance with local requirements. Information regarding lamp recycling and disposal can be found at www.lamprecycle.org