

WHD	H	10-046-001	ALD	4/6/10
WHD	I	10-044-003	ALD	4/20/10
WHD	J	10-044-004	ALD	8/18/10
APPR	REV	ISO DOC	BY	DATE

THIS PAGE IS ONLY A COVER SHEET

**SEE THE FOLLOWING PAGES FOR
ACTUAL INSTRUCTION SHEET**

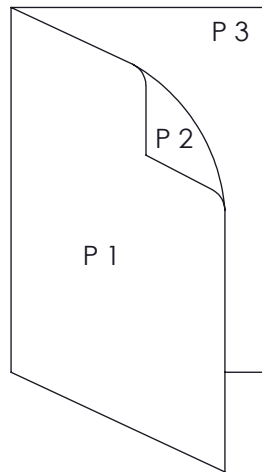

PHILIPS

100 Craftway, P.O. Box 128
Littlestown, Pennsylvania 17340-0128

CONFIDENTIAL: This drawing is confidential and proprietary to Philips and may not be reproduced in whole or in part without the express written consent of Philips. All rights reserved.
© 2010 by Philips Electronics.

DRW SIZE: A

TITLE:
INSTRUCTION SHEET, BU6 FOUNTAIN
LIGHT

UNLESS OTHERWISE SPECIFIED:
*ALL DIMENSIONS ARE IN INCHES.
*ALL THREADS ARE UNC-2B OR UNF-2B
AFTER COATING.
*ALL THREADS ARE TO BE VERIFIED
WITH A THREAD GAGE.

DRAWN BY: J. WOJTKOWIAK

DATE: 2/19/99

CHECKED BY: WHD

DATE: 7/16/08

APPR BY: E. HADDAD

DATE: 2/19/99

MATERIAL:
11.0 X 17.0 WHITE BOND PAPER, PRINTED
ON BOTH SIDES WITH BLACK INK, SEE
DIAGRAM ABOVE

* DO NOT SCALE THIS DRAWING *

EF-04-01-11 Rev.09

SCALE 1:1

SHEET 1 OF 4

PART NO: 32001023

PHILIPS

100 Craftway, P.O. Box 128
Littlestown, Pennsylvania 17340-0128

INSTALLATION INSTRUCTIONS: FOUNTAIN LIGHTING (NICHE TYPE)

WARNING: Do not remove labels from this fixture. Read and understand all warnings and installation procedures before continuing installation. Failure to follow these instructions may void warranty. **DANGER-Fatal electric shock can occur if underwater electrical equipment is not installed properly.** This equipment should only be installed by qualified electricians with proper grounding and ground fault interruption circuit breakers in accordance with National Electrical Code, Section 680, and all other applicable sections of the code.

E. FOUNTAINS

This part of the Code applies to permanently installed decorative fountains and reflecting pools in the ground, partially in the ground, or in a building. These units are primarily for aesthetic value and are not intended for swimming or wading.

This part of the Code does not cover installations in natural lakes, rivers, or ponds. However, it may be used in conjunction with the rest of the Code where electrical equipment is installed in a natural body of water.

680-50. General. The provisions of Part E shall apply to all fountains as defined in Section 680-4. Fountains that have water common to a pool shall comply with the pool requirements of this article.

Exception: Self-contained, portable fountains no larger than 5 ft. (1.52 m) in any dimension are not covered by Part E.

680-51. Lighting Fixtures, Submersible Pumps, and Other Submersible Equipment.

(a) Ground-Fault Circuit-interrupter. A ground-fault circuit-interrupter shall be installed in the branch circuit supplying fountain equipment.

Exception: Ground-fault circuit-interrupters shall not be required for equipment operating at 15 volts or less and supplied by a transformer complying with Section 680-5(a).

(b) Operating Voltage. All lighting fixtures shall be installed for operation at 150 volts or less between conductors. Submersible pumps and other submersible equipment shall operate at 300 volts or less between conductors.

(c) Lighting Fixture Lenses. Lighting fixtures shall be installed with the top of the fixture lens below the normal water level of the fountain unless approved for above-water locations. A lighting fixture facing upward shall have the lens adequately guarded to prevent contact by any person.

(d) Overheating Protection. Electric equipment that depends on submersion for safe operation shall be protected against overheating by a low-water cutoff or other approved means when not submerged.

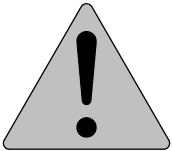

This fixture is intended for installation in accordance with the National Electrical Code and local code specifications. Failure to adhere to these codes and instructions may result in serious injury and/or damage to the ballast and void the warranty. These instructions do not purport to cover all details or variations in equipment, nor to provide for every possible contingency related to installation, operation, maintenance, or mounting situation. Should specific problems occur that are not addressed by these instructions, contact your Sales Representative or distributor for assistance. Retain these instructions for future reference.



SAFETY WARNING:

ALWAYS TURN FIXTURE OFF/DISCONNECT POWER AND ALLOW TO COOL BEFORE PERFORMING ANY MAINTENANCE, INCLUDING RELAMPING AND CLEANING!

This fixture can become very HOT! The fixture housing and lens, especially if it is glass, can become hot enough to blister hands. Attention should be paid to where the fixture is mounted, particularly if it can be touched by children or pets. To help prevent premature failure, decreased performance, overheating and risk of fire, keep fixture and lens clean and free of leaves, mulch, debris and mineral deposits from water. The fixture and lens can be cleaned using a soft cloth and a solution of mild liquid soap and warm water. Wipe clean and dry with a soft, lint-free dry cloth. Avoid polishing fixture or lens.

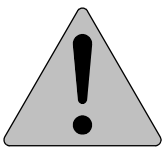

INSTRUCTIONS PERTAINING TO A RISK OF FIRE OR INJURY TO PERSONS IMPORTANT SAFETY INSTRUCTIONS - SAVE THESE INSTRUCTIONS!

WARNING - Lamp gets HOT quickly! To reduce the risk of FIRE OR INJURY TO PERSONS:

Do not operate fixture with a missing or damaged lens/lens assembly.

Contact only switch or plug when turning fixture on or off. Do NOT touch hot lens or housing.

Turn off or unplug fixture and allow to cool before relamping. Keep lamp away from combustibles.

Do NOT touch lamp with bare hands at any time, use a soft cloth as oil from skin may damage lamp.

(e) Wiring. Equipment shall be equipped with provisions for threaded conduit entries or be provided with a suitable flexible cord. The maximum length of exposed cord in the fountain shall be limited to 10 ft. (3.05 m). Cords extending beyond the fountain perimeter shall be enclosed in approved wiring enclosures. Metal parts of equipment in contact with water shall be of brass or other approved corrosion-resistant metal.

(f) Servicing. All equipment shall be removable from the water for relamping or normal maintenance. Fixtures shall not be permanently embedded into the fountain structure so that the water level must be reduced or the fountain drained for relamping, maintenance, or inspection.

(g) Stability. Equipment shall be inherently stable or be securely fastened in place.

680-52. Junction Boxes and Other Enclosures.

(a) General. Junction boxes and other enclosures used for other than underwater installation shall comply with Sections 680-21 (a) (1), (2), and (3); and (b), (c), and (d).

(b) Underwater Junction Boxes and Other Underwater Enclosures. Junction boxes and other underwater enclosures shall be submersible and (1) be equipped with provisions for threaded conduit entries or compression glands or seals for cord entry; (2) be of copper, brass or other approved corrosion resistant material; (3) be filled with an approved potting compound to prevent the entry of moisture; (4) be firmly attached to the supports or directly to the fountain surface and bonded as required. Where the junction box is supported only by the conduit, the conduit shall be of copper, brass, or other approved corrosion-resistant metal. Where the box is fed by nonmetallic conduit, it shall have additional supports and fasteners of copper, brass, or other approved corrosion-resistant material.

(FPN) See Section 370-23 for support of enclosures.

680-53. Bonding. All metal piping systems associated with the fountain shall be bonded to the equipment grounding conductor of the branch circuit supplying the fountain.

(FPN) See Section 250-95 for sizing of these conductors.

680-54. Grounding. The following equipment shall be grounded: (1) all electric equipment located within the fountain or within 5 ft. (1.52 m) of the inside wall of the fountain; (2) all electric equipment associated with the recirculating system of the fountain; (3) panel boards that are not part of the service equipment and that supply any electric equipment associated with the fountain.

680-55. Methods of Grounding.

(a) Applied Provisions. The provisions of Section 680-25 shall apply, excluding paragraph (e).

(b) Supplied by a Flexible Cord. Electric equipment that is supplied by a flexible cord shall have all exposed noncurrent-carrying metal parts grounded by an integral part of this cord. This grounding conductor shall be connected to a grounding terminal in the supply junction box, transformer enclosure, or other enclosure.

680-56. Cord- and Plug-Connected Equipment.

(a) Ground-Fault Circuit-Interrupter. All electric equipment, including power-supply cords, shall be protected by ground-fault circuit-interrupters.

(b) Cord Type. Flexible cord immersed in or exposed to water shall be of the hard-service type as designated in Table 400-4 and shall be marked water resistant.

(c) Sealing. The end of the flexible cord jacket and the flexible cord conductor termination within equipment shall be covered with, or encapsulated in, a suitable potting compound to prevent the entry of water into the equipment through the cord or its conductors. In addition, the ground connection within equipment shall similarly treated to protect such connections from the deteriorating effect of water that may enter into the equipment.

(d) Terminations. Connections with flexible cord shall be permanent, except that grounding-type attachment plugs and receptacles shall be permitted to facilitate removal or disconnection for maintenance, repair, or storage of fixed or stationary equipment not located in any water-containing part of a fountain.

680-11. Equipment Rooms and Pits. Electric equipment shall not be installed in rooms or pits that do not have adequate drainage to prevent accumulation during normal operation or filter maintenance.

680-12. Disconnecting Means. Disconnecting means shall be accessible, located within sight from pool, spa, or hot tub equipment, and shall be located at least 5 ft (1.52 m) horizontally from the inside walls of the pool, spa, or hot tub.

This section is new in the 1996 Code. A disconnecting means is required for the pool, spa, and hot tub equipment to allow service personnel to disconnect the power while servicing these units.

SERVICE

DANGER: DISCONNECT POWER BEFORE SERVICING.

1. When relamping fixtures, inspect gaskets, cord seals, socket and cord for possible worn and/or dangerous conditions that may become a fatal shock hazard. Do not use higher wattage lamp.
2. Do not reinstall in the fixture cracked or worn gaskets, lens, cord seal, socket, cord, or any damaged equipment.
3. Bronzelite/Hadco recommends replacing gaskets when relamping fixtures.
4. See Bronzelite/Hadco catalog for replacement parts.
5. Do not convert pool to salt water.

CORROSIVE WATER CONDITIONS WARNING:

Excessive use of bromine or chlorine in water can cause a corrosive environment for bronze alloy light fixtures. Proper pH balance above 7.0 should be maintained at all times to eliminate the risk of corrosion. A natural patina process of the fixture may occur in these conditions and is not harmful in any way.

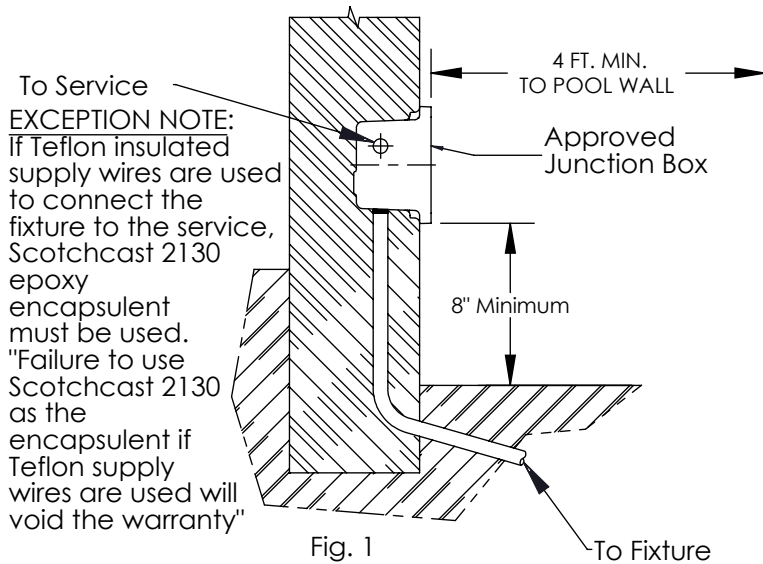

EXCEPTION NOTE:
If Teflon insulated supply wires are used to connect the fixture to the service, Scotchcast 2130 epoxy encapsulent must be used. "Failure to use Scotchcast 2130 as the encapsulent if Teflon supply wires are used will void the warranty"

Fig. 1

INSTRUCTION SHEET FOR FOUNTAIN LIGHTS WITH NICHE

WARNING: OPERATE SUBMERGED ONLY. FRESH WATER USE ONLY.

1. Position niche plumb and level. Make sure the location of the niche is below the fountain water level in accordance with N.E.C. 680.
2. Attach conduit to threaded hub provided at back of niche. Run separate ground wire (#8 AWG) from pressure type grounding lug furnished on the niche to reinforcing on structural metal of pool. (See fig. 2)
3. After concrete has been poured and finished surface of the pool has been applied flush with the niche lip, insert flexible cord furnished with fixture into conduit and run as unbroken continuous cord to approved junction box. Make water-proof connection to the junction box using conventional pipe sealant. Seal around all wires and splices with SWS 930 silicone sealant or another nonacetic acid cure type sealant.

IMPORTANT - To prevent water entry into junction compartment, **conduit entries must be sealed, and potting of the entire compartment is required.** Recommended potting compounds: Hadco/Bronze lite catalog number MA1, PC-4000, RTV Silicone or paraffin wax. **Failure to pot wiring compartment may void warranty.** See exception note in Fig. 1. Fixture provided with customer specified length of cord, plus 5 feet, of which approximately 6

feet is available for service of the fixture.
CAUTION: Do not splice cord except at end in an approved junction box. (See fig. 1)
4. Open fixture and install proper lamp of correct wattage given on the fixture label. Replace lens torque down all retaining screws to 23 in./lbs. for the BU6 fixture, and 58 in./lbs. for the 5100 and 6100 fixtures. Use the "Criss Cross" method of tightening

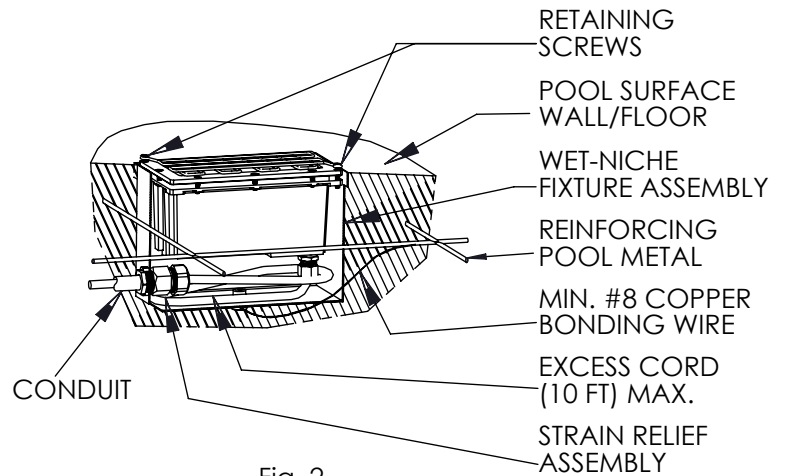

Fig. 2

4. Coil excess cord around fixture housing and install fixture in niche. Make sure that fixture mounting lug of the lens ring interlocks with the lug of the niche mounting ring (See fig. 2). Insert tamper-proof stainless steel retaining screw in hole provided at top of lens ring. Tighten to 23 in./lbs. Screws 9-10.

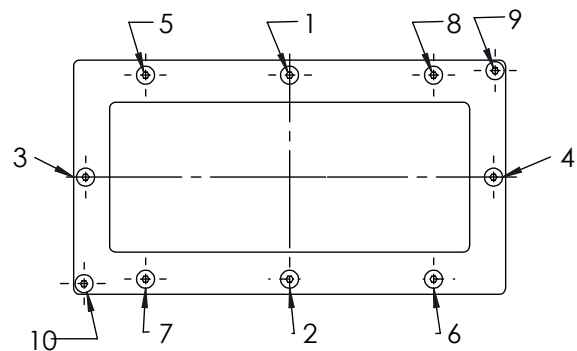

Fig. 3

